

SFE-SA

SEMI-AUTOMATIC SLEEVE WRAPPER



FIELDS OF APPLICATION

FOOD

BEVERAGE

DETERGENTS AND CHEMICALS

TISSUE

LOGISTIC

INDUSTRIAL PRODUCTS

COSMETICS AND PHARMACEUTICALS

Semi-automatic sleeve wrapper with manual loading, ideal for small or medium speed production, where packs can be single or collated and frequently changed in size and shape.

Total closing of the pack by film overlapping.

RECOMMENDED FOR:

- sticks
- cans
- jerry cans
- industrial products
- boxes
- bottles
- bricks, bags
- paper rolls
- jars
- aerosols

IMPROVE YOUR PACKAGING LINE

SEMI - AUTOMATIC SLEEVE - WRAPPER <SA> STANDARD

MODELS	SFE 600	SFE 800	SFE 1100	SFE 1500
Max. product height (mm)**	280	330	400	400
Sealing bar width (mm)	560	760	1070	1470
Max. film width (mm)	500	700	1000	1400
Production speed (packs/min)	15	15	15	15
Shrink tunnel installed power (kw)**	8,8	17,4	20,2	27

Available with sealer unit separated from the tunnel.

** Customizable heights; Customizable voltages

SEMI - AUTOMATIC SLEEVE - WRAPPER <SA> CUSTOMIZATIONS

LONGER LOADING TABLES

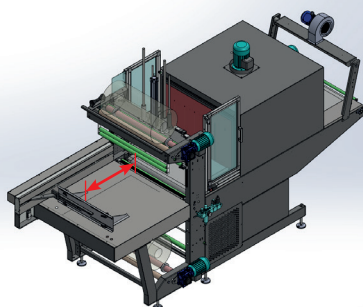

	MAXIMUM PRODUCT LENGTH (MM)	
	STANDARD	OPTIONAL
SFE 600	350
SFE 800	450	800
SFE 1100	450	800
SFE 1500	650	1000/1400

HIGHER VERSIONS

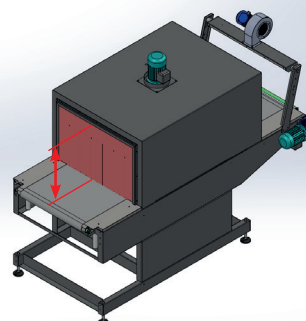

	MAXIMUM PRODUCT HEIGHT (MM)	
	STANDARD	OPTIONAL
SFE 600	280	420
SFE 800	330	420
SFE 1100	400	600
SFE 1500	400	600

OPTIONALS

- Pusher automation
- Tamping rollers at the outlet
- Castors
- Custom RAL on demand
- Machines in stainless steel



L.P. PACKAGING S.r.l.

Via Europa 3a
40010 Sala Bolognese (BO)
ITALY Tel. +39 051 860013
info@lp-packaging.it

L.P. Packaging srl reserves the right to change the design and/or specification of products without prior notice. Part of this information is general only; the Customer must ensure they apply to their needs; some functions are optional; out of scale drawings are valid as a description only.



www.lp-packaging.it